

GRU A MONTAGGIO RAPIDO
 GRUE A MONTAGE RAPIDE
 GRUA DE RAPIDO MONTAJE
 GRUA DE MONTAGEM RAPIDA
 QUICK SELFERECTING CRANE
 HYDRAULISCHER SCHNELLMONTAGEKRAN

Curve di carico – Courbes de charges – Load diagrams – LastKurven – Curvas de cargas

	3 25 30,3	m	OP	3 25 30,3	m
	800 800 800	kg		1000 1000 1000	kg
	3 10.3 12 16 20 24 28 31	m			
	4000 4000 3385 2345 1765 1400 1145 1000	kg			
	3		18.5 20 24 28 31	m	
	2000		2000 1865 1500 1240 1100	kg	
	3	15.5 16 20 24 28 31	m		
	2500	2500 2445 1865 1500 1240 1100	kg		
	3 11.3 14.4	m			
	4000 4000 3000	kg			
	3 14.4	m			
	2000 2000	kg			
	3 14.4	m			
	2500 2500	kg			

Reazioni – Reactions – Réactions – Eckdrücke – Reacciones – Reações

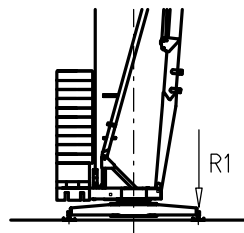

R1 ● 22 t ■ 15 t

▲ 12.7 t ◆ 25.6 t

{ N°2 A=3500Kg (1750Kgx2)
N°2 B=2100Kg (1050Kgx2)
N°16 C=20000Kg (1250Kgx16)

- | | | |
|-------------------------------|---------------------------------------|--------------------------------------|
| ● Reazioni in servizio | ● Reactions in service | ● Réactions en service |
| ■ Reazioni fuori servizio | ■ Reactions out of service | ■ Réactions hors service |
| ▲ Peso della gru senza assali | ▲ Dead weight without transport axles | ▲ Poids de construction sans essieux |
| ◆ Peso zavorra rotante | ◆ Ballast weight | ◆ Poids du lest |
-
- | | | |
|--|--|---|
| ● Reaktionskräfte in betrieb | ● Reacciones en servicio | ● Em serviço |
| ■ Reaktionskräfte außer betrieb | ■ Reacciones fuera de servicio | ■ Fora de serviço |
| ▲ Konstruktionsgewicht ohne transportachse | ▲ Peso de la grua sin tren de transporte | ▲ Peso de la grua sem carro de transporte |
| ◆ Ballastgewicht | ◆ Peso de lastre | ◆ Peso de lastre rotativo |

Montaggio – Montage – Erection – Montage – Montaje – Montagem

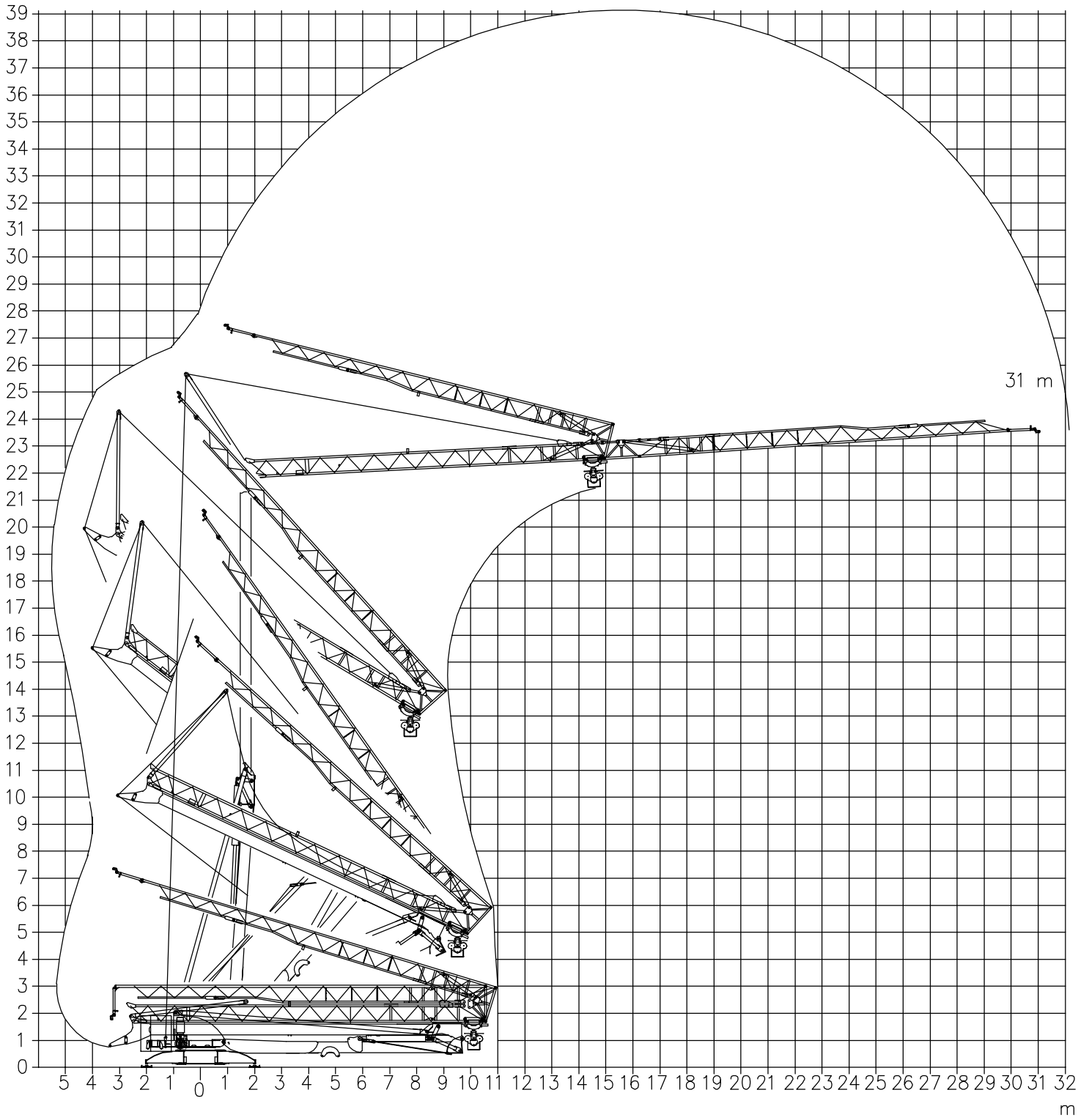

Trasporto

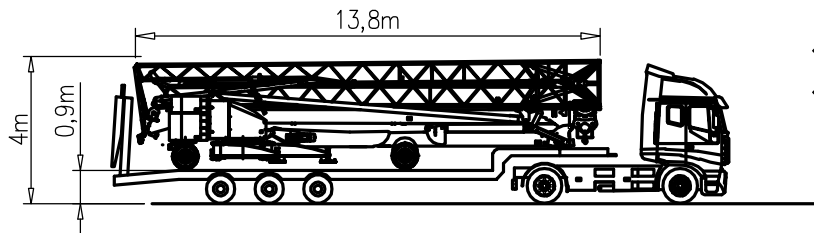

- ◆ Blocchi A 2x1750=3500 Kg
- ◆ Blocchi B 2x1050=2100 Kg

Peso di Trasporto (Blocchi A+B) Kg 19100

Traino 5Km/h

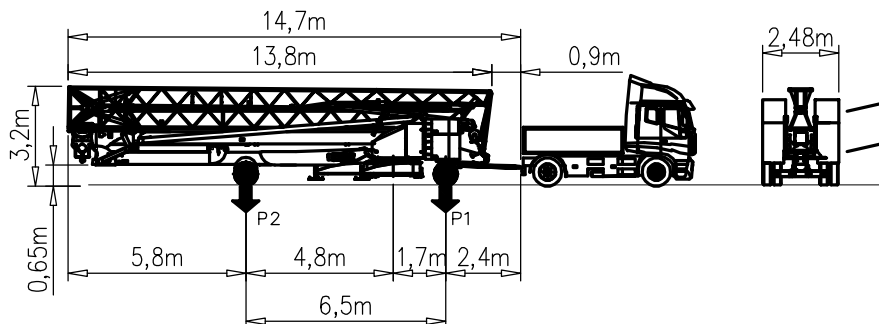

- ◆ Blocchi B 2x1050=2100 Kg
- ◆ Blocchi A 2x1750=3500 Kg

P1	Kg	9260
P2	Kg	9840
Ptot	Kg	19100

Traino 25Km/h

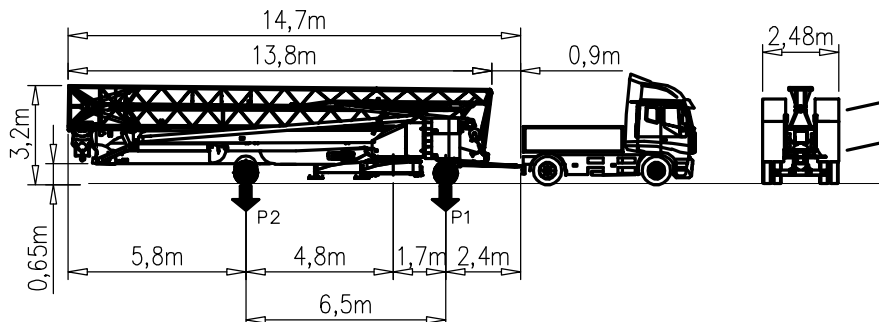

- ◆ Blocchi B 2x1050=2100 Kg
- ◆ Blocchi A 2x1750=3500 Kg

P1	Kg	9690
P2	Kg	10060
Ptot	Kg	19750

Traino 80Km/h

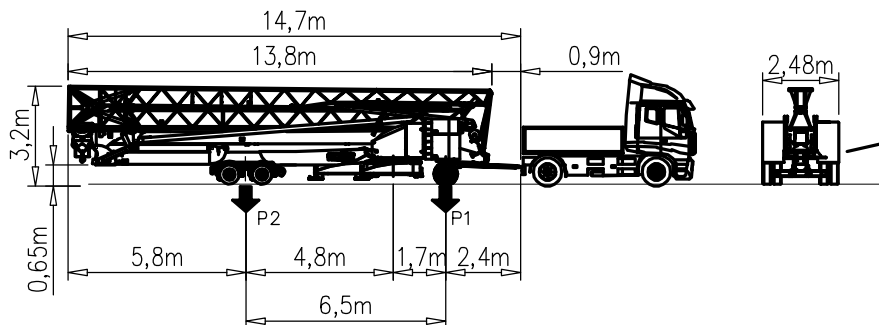

- ◆ Blocchi A 2x1750=3500 Kg





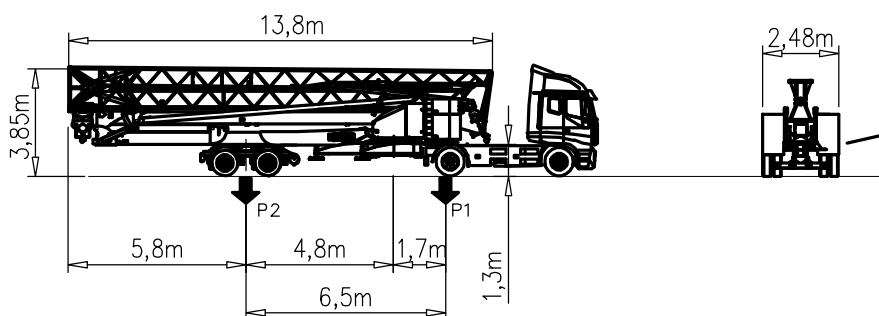

P1	Kg	8190
P2	Kg	11360
Ptot	Kg	19550



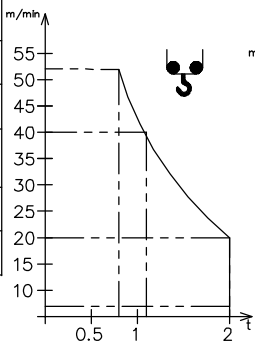
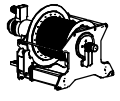

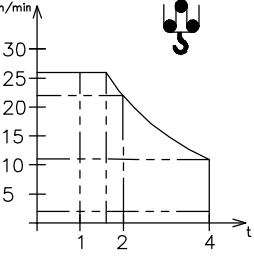
Traino 80Km/h

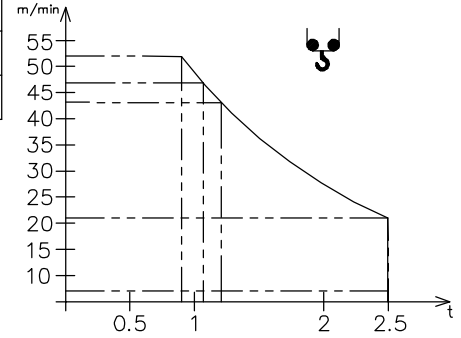
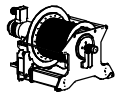

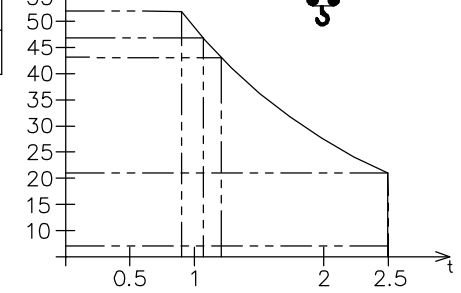
- ◆ Blocchi A 2x1750=3500 Kg

P1	Kg	8190
P2	Kg	11360
Ptot	Kg	19550

V12.40 Sollevamento Hoisting Levage Heben Elevaci�n Eleva�o	m/min t	 <table border="1"> <tr> <td>4</td> <td>22</td> <td>40</td> <td>52</td> <td></td> </tr> <tr> <td>2.0</td> <td>2.0</td> <td>1.1</td> <td>0.8</td> <td></td> </tr> </table>	4	22	40	52		2.0	2.0	1.1	0.8			V12.40 8.8 kW (12 Hp) 18 kVA 
	4	22	40	52										
2.0	2.0	1.1	0.8											
m/min t	 <table border="1"> <tr> <td>2</td> <td>11</td> <td>20</td> <td>26</td> <td>26</td> </tr> <tr> <td>4.0</td> <td>4.0</td> <td>2.0</td> <td>1.6</td> <td>1.0</td> </tr> </table>	2	11	20	26	26	4.0	4.0	2.0	1.6	1.0			
2	11	20	26	26										
4.0	4.0	2.0	1.6	1.0										
V15.45 Sollevamento Hoisting Levage Heben Elevaci�n Eleva�o	m/min t	 <table border="1"> <tr> <td>4</td> <td>21</td> <td>44</td> <td>46</td> <td>52</td> </tr> <tr> <td>2.5</td> <td>2.5</td> <td>1.25</td> <td>1.1</td> <td>0.9</td> </tr> </table>	4	21	44	46	52	2.5	2.5	1.25	1.1	0.9		V15.45 11 kW (15 Hp) 20 kVA 
	4	21	44	46	52									
2.5	2.5	1.25	1.1	0.9										
m/min t	 <table border="1"> <tr> <td>4</td> <td>21</td> <td>44</td> <td>46</td> <td>52</td> </tr> <tr> <td>2.5</td> <td>2.5</td> <td>1.25</td> <td>1.1</td> <td>0.9</td> </tr> </table>	4	21	44	46	52	2.5	2.5	1.25	1.1	0.9			
4	21	44	46	52										
2.5	2.5	1.25	1.1	0.9										

Carrello Trolleying Distribution Katzfahren Distribuci�n Distribu�o			1a 2a 3a	0 → 45	m/min	2.2 kW / 3 kW
			1a 2a	0 → 17	m/min	3 kW
			1a 2a	0 → 17	m/min	3 kW
Rotazione Slewing Orientation Schwenken Orientaci�n Rota�o			1a 2a 3a	0 → 0.8	giri/min tr/min rp/min	2.2 kW

	400V – 50 Hz
Potenza elettrica necessaria – Puissance �lectrique n�cessaire Necessary electric power – Anschlusswert – Potencia electrica necesaria	V12.40 18 kVA V15.45 20 kVA
Conforme alla direttiva 2000/14/CE sul livello acustico Conforme � la directive 2000/14/CE sur le niveau acoustique In compliance with the 2000/14/CE instruction on noise level Germ�ss EWG-Richtlinie 2000/14/CE �ber Schall-Leistungspegel Conforme con la directiva 2000/14/CE sobre el nivel acustico	FEM 1.001–A3

 FMgru s.r.l.
 via Emilia 11–29010 Pontenure PC ITALY
 tel. 0523/510446 ric.aut. fax 0523/510365
 www.fmgru.it e-mail: info@fmgru.com



Documento commerciale non contrattuale
 Per tutte le informazioni tecniche riferirsi
 alle corrispondenti istruzioni

Unverbindliches Vertriebsdokument.
 F r technische Informationen, siehe die
 entsprechenden Anweisungen.

This commercial document is not legally
 binding. For any technical information, please
 refer to the corresponding instructions.

Documento comercial no contractual
 Para cualquier informaci n t cnica,
 ver la noticia correspondiente.

Code: 15ICA37B61A0	
Ed. Data	Rev Data
1 24.07.06	4 29.06.20